



IQ Laboratory

ES Estamos encantados de presentarles nuestra colección de cajas secretas con la que estamos seguros van a disfrutar mucho. Hemos creado una historia cuyo protagonista es señor Biorg (usted) y para conocer el final tendrá que resolver la trilogía completa. Puede mirar el inicio de la historia en el código QR que aparece impreso en la caja. Cada edificación tiene un nivel de dificultad diferente. Si tiene problemas con la lectura del código QR póngase en contacto con: customerservice@aquamarinegames.es

EN We are delighted to present our collection of secret boxes which we are sure you will enjoy very much. We have created a story whose main character is Mr. Biorg (you) and to find out the ending you will have to solve the whole trilogy. You can see the beginning of the story in the QR code printed on the box. Each building has a different level of difficulty. . If you have problems reading the QR code please contact: customerservice@aquamarinegames.es

PT Temos o prazer de lhe apresentar a nossa coleção de caixas secretas, que temos a certeza que vai gostar muito. Criámos uma história cuja personagem principal é o Sr. Biorg (tu) e, para descobrir o final, terás de resolver toda a trilogia. Podes ver o início da história no código QR impresso na caixa. Cada edifício tem um nível de dificuldade diferente. Se tiver problemas com a leitura do código QR, contacte: customerservice@aquamarinegames.es

The Madhouse

ES El objetivo es abrir los compartimentos de The Madhouse mediante una serie de movimientos de algunas de sus partes y ayudar a salir a los ocupantes. Desde nuestro laboratorio de Ingenio, recomendamos no mirar las ayudas en las soluciones

EN The objective is to open the compartments of The Madhouse through a series of movements of some of its parts and help the occupants to get out. From our Ingenuity Lab, we recommend not to look at the help in the solutions.

PT O objetivo é abrir os compartimentos do Madhouse através de uma série de movimentos de algumas das suas partes e ajudar os ocupantes a sair..A partir do nosso Laboratório de Engenho, recomendamos que não olhe para a ajuda nas soluções

aquamarine games®



IQ Laboratory

FR Nous sommes ravis de vous présenter notre collection de boîtes à secrets qui, nous en sommes sûrs, vous plaira beaucoup. Nous avons créé une histoire dont le personnage principal est M. Biorg (vous) et pour découvrir la fin, vous devrez résoudre toute la trilogie. Vous pouvez voir le début de l'histoire dans le code QR imprimé sur la boîte. Chaque bâtiment a un niveau de difficulté différent. Si vous avez des problèmes pour lire le code QR, contactez-nous : customerservice@aquamarinegames.es

DE Wir freuen uns, Ihnen unsere Sammlung von geheimen Schachteln vorzustellen, die Ihnen sicher viel Freude bereiten wird. Wir haben uns eine Geschichte ausgedacht, deren Hauptfigur Herr Biorg (Sie) ist. Um das Ende herauszufinden, müssen Sie die ganze Trilogie lösen. Du kannst den Anfang der Geschichte in dem QR-Code auf der Schachtel sehen. Jedes Gebäude hat einen anderen Schwierigkeitsgrad. Wenn Sie Probleme mit dem Lesen des QR-Codes haben, wenden Sie sich bitte an: customerservice@aquamarinegames.es

Madhouse

FR L'objectif est d'ouvrir les compartiments de The Madhouse par une série de mouvements de certaines de ses pièces et d'aider les occupants à sortir.
et d'aider les occupants à sortir.
Dans notre laboratoire d'ingéniosité, nous recommandons de ne pas regarder l'aide dans les solutions.

DE Das Ziel ist es, die Abteile des Irrenhauses durch eine Reihe von Bewegungen einiger seiner Teile zu öffnen und den Insassen zu helfen, herauszukommen.
und den Bewohnern zu helfen, herauszukommen.
Von unserem Ingenuity Lab empfehlen wir, nicht auf die Hilfe in den Lösungen zu schauen.



Help me professor aquamarine!

Madhouse es una interesante caja con cinco celdas en su interior. Cuatro celdas pueden ser liberadas, así que ayuda a salir a los habitantes. Hay tres compartimentos dentro de la caja que necesitan ser abiertos. Atención el nivel de dificultad es muy alto.

Aquí hay algunas guías para el manual:

1. El deslizador 1,2,3,4 se refiere a la barra marcada con I,II,III,IV y que se puede mover. Por favor, coloque la caja de la manera como muestra la foto. Asegúrese de colocar los controles deslizantes en la posición correcta para permitir que los controles deslizantes se puedan mover, o

Por favor, ajústelo hasta que el otro deslizador pueda pasar.

2. En la siguiente foto hay señales "+,-" que indican la dirección en la que se deben empujar los deslizadores.

3. la palabra "end" significa que debe empujar la barra en la dirección solicitada hasta que el deslizador no pueda moverse más. no se pueda mover más

4. hay señales como ○,□,△,△,☆..... Asegúrese de no ignorarlas, estas señales indican que necesita empujar el deslizador hasta la posición de la señal.

5. La solución incluye cómo abrir la caja y cómo cerrarla.

6. Cuando la solución marca "-end" o "+ end". Significa que tiene que empujar el control deslizante que no se puede mover más.

Por último, espero que pueda disfrutar de su tiempo con esta caja de Escape especial.

¿Cómo abrir la Madhouse?

El orden para abrir todas las habitaciones es el siguiente:

La tapa grande llamada Tapa 1

hay que moverla primero,

a continuación, abrir el más pequeño

más pequeña llamada Tapa 2. Por último,

abra la tapa 3.

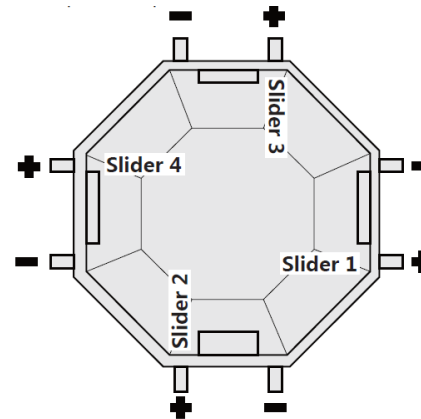

A Escape Box é uma caixa interessante com cinco células no interior. Quatro células podem ser libertadas, por isso ajuda-as a sair. para sair. Há três compartimentos no interior da caixa que têm de ser abertos. O nível de dificuldade é elevado.

Eis algumas directrizes para o manual:

6 O cursor 1,2,3,4 refere-se à barra marcada com I,II,III,IV e pode ser movido. Colocar a caixa como mostra a figura. como indicado na imagem. Certifique-se de que coloca os cursores na posição correcta para permitir que os cursores se desloquem, ou

que os cursores se movam, ou

Ajuste-o até que o outro cursor possa passar.

† Na figura seguinte, há sinais "+,-" que indicam a direcção em que os cursores devem ser empurrados.

† a palavra "fim" significa que deve empurrar a barra na direcção pretendida até que a barra deslizante deixe de se poder mover. não pode mover-se mais.

∞ Existem sinais como  até à posição do sinal.

o A solução inclui a forma de abrir a caixa e de a fechar.

c Quando a solução assinala "- fim" ou "+ fim". Significa que tens de empurrar o cursor que não pode ser movido mais. mais.

Por fim, espero que te divirtas com esta caixa de fuga especial.

Como abrir a Madhouse?

A ordem para abrir todas as salas as salas é a seguinte:

A tampa grande chamada Tampa 1 tem de a mover primeiro, depois abrir a tampa mais pequena, chamada Tampa 2. Por fim, abre a tampa 3.

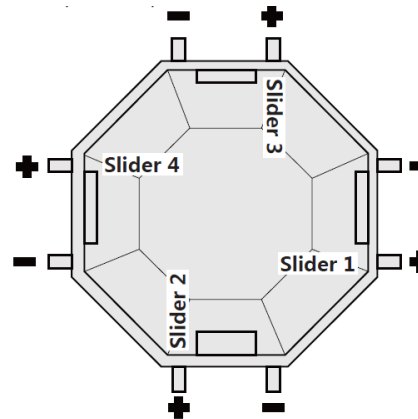

1. Slider + End
2. Slider 2 + End
3. Slider - End
4. Slider - End
5. Slider - End
6. Slider 2 + End
7. Slider 1 + End
8. Slider - ○
9. Slider 4 + End
10. Slider 2 + End

11. Slider - End
12. Slider - End
13. Slider - End
14. Slider + End
15. Slider + End
16. Slider + End
17. Slider - End
18. Quitar la tapa 1 y saque la cerradura A (que se encuentra en el compartimento).

19. Slider + End
20. Slider - ○
21. Slider - End
22. Slider - End
23. n the box over and remove lid 2

24. Slider + ○
25. Slider + ∩
26. Slider + ☆
27. Slider - End
28. Slider - End
29. Slider + △
30. Slider + End
31. Slider + End
32. Slider - End

33. Slider - End
34. Slider + End
35. Slider - End
36. Slider - ○
37. Slider + △
38. Slider + End
39. n the box over and remove lid 3

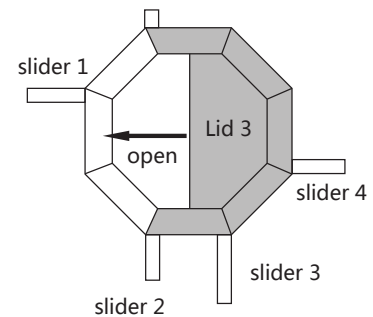
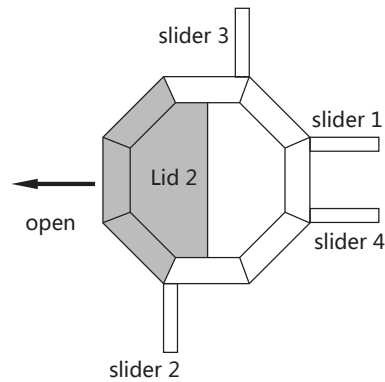
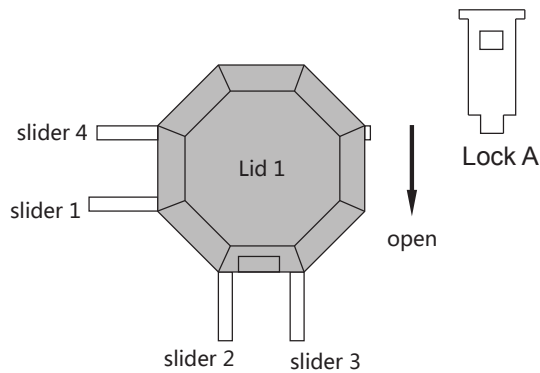

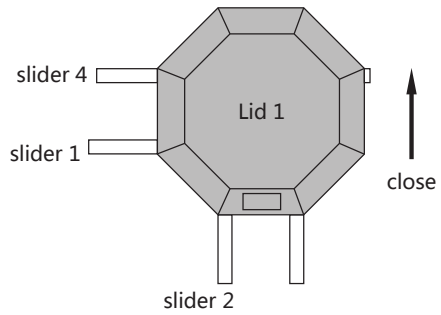

1. Slider 2: + end
2. Slider 1: - end
3. Introduzca la cerradura A en el compartimento central
4. colocar las cubetas yy cerrar la tapa 1.

1. Slider 2: + end
2. Slider 1: end
3. inserir o cadeado A no compartimento central
4. Colocar as cubetas e fechar a tampa 1..

¿Cómo cerrar la Madhouse?

ES El orden de cierre de la cara es inverso al de apertura, empezando por la Tapa 3, luego la Tapa 2, después la Tapa 1, y finalmente ajustando los deslizadores a las posiciones iniciales.

CCómo fechar o Madhouse?

PT A ordem de fecho da face é a inversa da ordem de abertura, começando pela Tapa 3, depois Tapa 2, depois Tapa 1 e, finalmente, ajustando a Tapa 1 e, finalmente, ajustando os selectores para as posições iniciais.

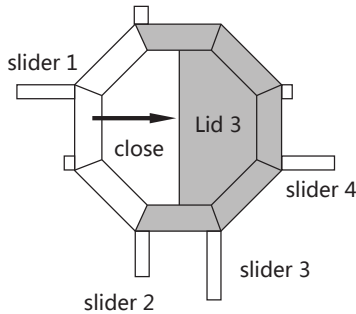
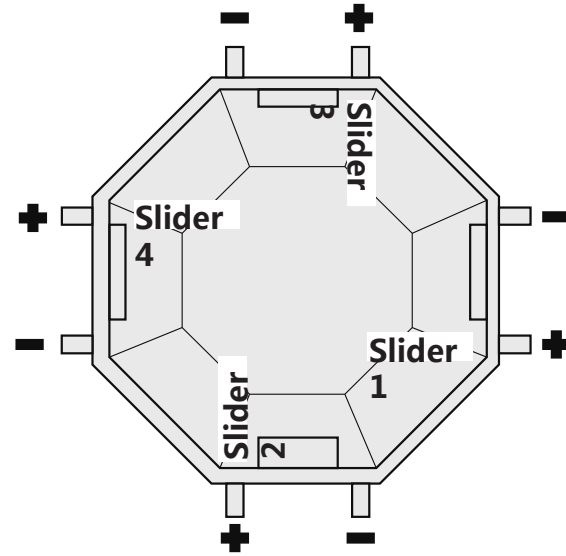

ES

CColoque la célula en el compartimento y cierre la tapa 3 siguiendo la flecha.

PT

Colocar a célula no compartimento e fechar a tampa 3 de acordo com a seta.

1. Slider 3: - \triangle	10. Slider 3: - end
2. Slider 4: - end	11. Slider 4: + end
3. Slider 2: + end	12. Slider 1: + end
4. Slider 1: + end	13. Slider 2: - \circ
5. Slider 2: - \circ	14. Slider 4: - end
6. Slider 4: + end	15. Slider 2: - end
7. Slider 2: + end	16. Da la vuelta a la caja y mete la célula, luego cierra la tapa 2
8. Slider 1: - end	
9. Slider 4: - end	

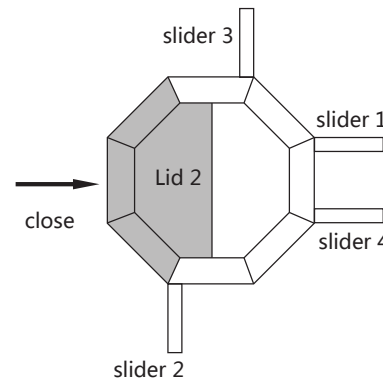

1. Slider 3: - \triangle	10. Slider 3: - end
2. Slider 4: - end	11. Slider 4: + end
3. Slider 2: + end	12. Slider 1: + end
4. Slider 1: + end	13. Slider 2: - \circ
5. Slider 2: - \circ	14. Slider 4: - end
6. Slider 4: + end	15. Slider 2: - end
7. Slider 2: + end	16. Da la vuelta a la caja y mete la célula, luego cierra la tapa 2.
8. Slider 1: - end	
9. Slider 4: - end	

16. Virar a caixa ao contrário, introduzir a célula e fechar a tampa 2.

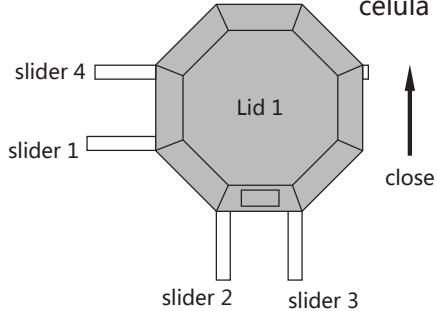

1. Slider 2: + end
2. Slider 1: - end
3. Inserte la cerradura A en el compartimento central
3. Inserte a tampa A no compartimento central.
4. colocar las cubetas y cerrar la tapa 1.
4. colocar as cuvetes nas cuvetes e fechar a tampa 1.

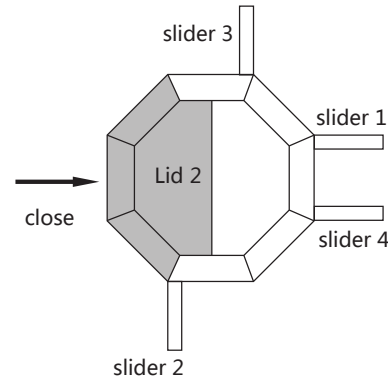

1. Slider 1: + end	10. Slider 2: - end	19. Slider 2: - end
2. Slider 2: - \circ	11. Slider 4: - end	
3. Slider 4: + \square	12. Slider 2: + end	
4. Slider 2: + end	13. Slider 1: - end	
5. Slider 1: - end	14. Slider 2: - \circ	
6. Slider 4: - end	15. Slider 4: + end	
7. Slider 3: + \triangle	16. Slider 2: + end	
8. Slider 1: + end	17. Slider 1: + end	
9. Slider 4: + end	18. Slider 3: - end	



















ES Ajuste los controles deslizantes a las posiciones iniciales

PT Ajustar os selectores para as posições iniciais

Manual for the Madhouse

The Madhouse is an interesting box with five cells inside. Four cells can be released so please help them come out. There are three compartments inside the box which need to be opened. The difficult level is high.

Here is some guides for the manual:

1. slider 1,2,3,4 refer to the bar marked with , , , and  which can be moved. Please place the box in the way as the photo shows. Make sure you place the sliders in the correct position to let the sliders can move, or please adjust it until the other slider can go through.
2. there are signals "+, -" in the following photo which means the directions that the sliders need to be pushed.
3. the word "end" means you need to push the bar along the direction requested until the slider cannot be moved any more.
4. there are signals like , , , , , , , , , , , , ,  on the wood bars, make sure you will not ignore them. These signals mean you need to push the slider to the position of the signal.
5. The solution includes how to open the box as well as how to close the box.
6. When the solution marked " -end" or "+ end" . It means need to push the slider that it cannot be moved any more.

At last , hope you can enjoy the time with this special Escape box .

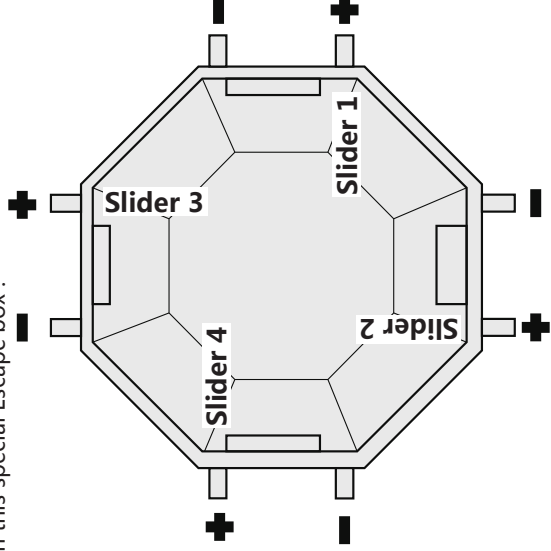

How to open the Madhouse?

The order of how to open all the rooms is as following:

The big cover called Lid 1 need to be moved first, then to open the smallest cover called Lid2. At last, open Lid 3.

1. Slider 3: + End	11. Slider 1: - End
2. Slider 2: + End	12. Slider 4: - End
3. Slider 1: - End	13. Slider 3: - End
4. Slider 2: - End	14. Slider 1: + End
5. Slider 4: - End	15. Slider 4: + End
6. Slider 2: + End	16. Slider 2: + End
7. Slider 1: + End	17. Slider 1: - End
8. Slider 2: - ○	18. remove lid 1 then take out lock A(which is in the center compartment .
9. Slider 4: + End	
10. Slider 2: + End	

19. Slider 1: + End	24. Slider 2: + ○	33. Slider 4: - End
20. Slider 2: - ○	25. Slider 4: + ○	34. Slider 2: + End
21. Slider 4: - End	26. Slider 2: + ☆	35. Slider 1: - End
22. Slider 2: - End	27. Slider 1: - End	36. Slider 2: - ○
23. turn the box over and remove lid 2	28. Slider 4: - End	37. Slider 4: + △
	29. Slider 3: + △	38. Slider 3: + End
	30. Slider 4: + End	39. turn the box over and remove lid 3
	31. Slider 1: + End	
	32. Slider 2: - End	

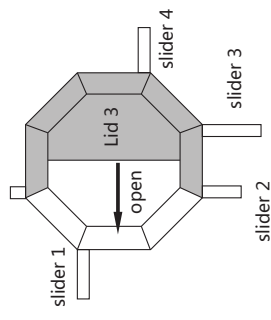
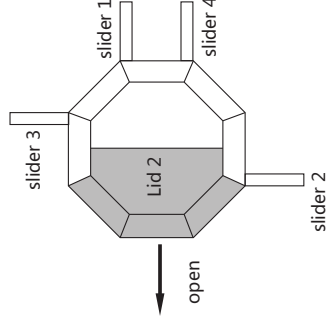
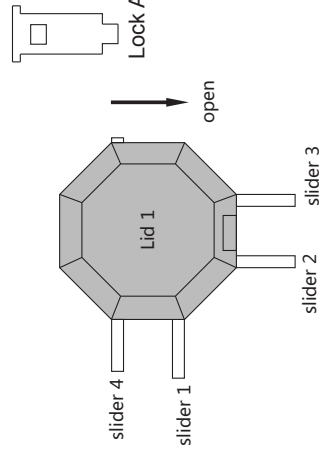

How to close the Madhouse?

The order of closing the box is opposite of opening the box, starting with the Lid 3, then the Lid 2, then the Lid 1, and finally adjusting the sliders to the initial positions.

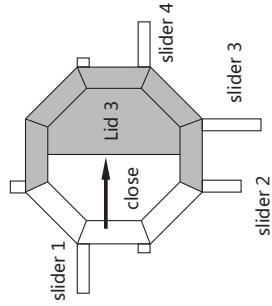

put the cell in the compartment, then close the Lid 3 along the arrow way.

1. Slider 3: - △	10. Slider 3: - end
2. Slider 4: - end	11. Slider 4: + end
3. Slider 2: + end	12. Slider 1: + end
4. Slider 1: + end	13. Slider 2: - ○
5. Slider 2: - ○	14. Slider 4: - end
6. Slider 4: + end	15. Slider 2: - end
7. Slider 2: + end	16. turn the box over and put the cell in, then close the lid 2
8. Slider 1: - end	
9. Slider 4: - end	

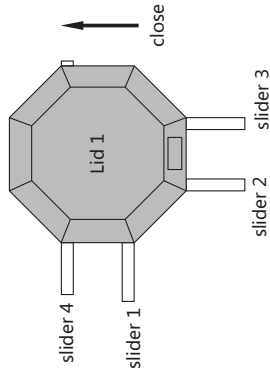

1. Slider 2: + end
2. Slider 1: - end
3. Insert lock A in the middle compartment .
4. put the cells in and close the lid 1.

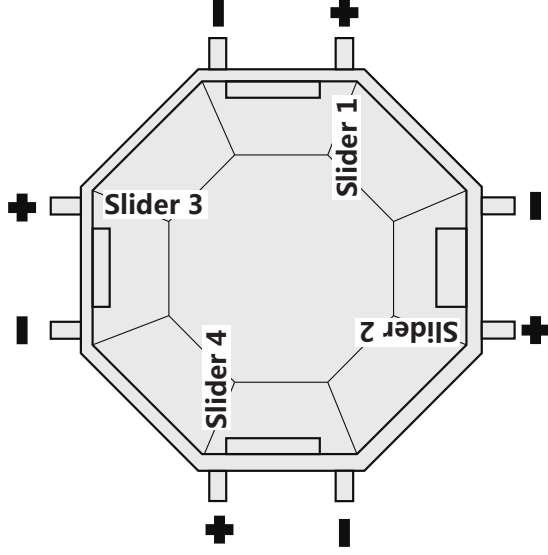
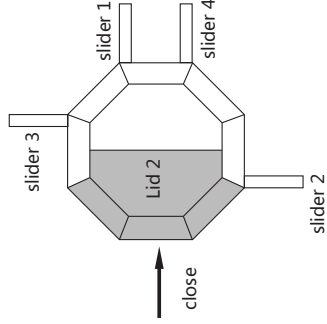

Adjust the sliders to the initial positions

1. Slider 1: + end	10. Slider 2: - end	19. Slider 2: - end
2. Slider 2: - ○	11. Slider 4: - end	
3. Slider 4: + ○	12. Slider 2: + end	
4. Slider 2: + end	13. Slider 1: - end	
5. Slider 1: - end	14. Slider 2: - ○	
6. Slider 4: - end	15. Slider 4: + end	
7. Slider 3: + △	16. Slider 2: + end	
8. Slider 1: + end	17. Slider 1: + end	
9. Slider 4: + end	18. Slider 3: - end	

La Trilogía / The Trilogy / A Trilogía

Nivel de dificultad/ Difficult level / nível de dificuldade

Medium***

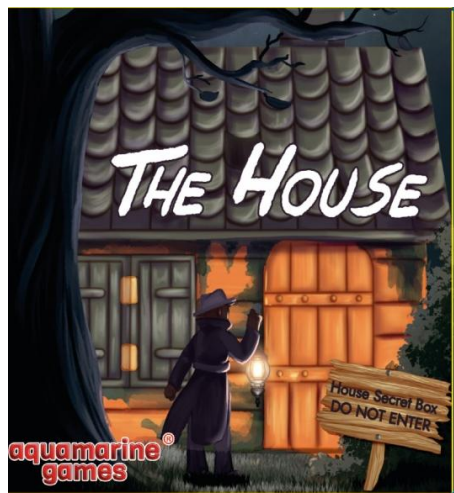

**No incluido en este pack
Not included in this pack
Não incluído neste pack**

Master ****



**No incluido en este pack
Not included in this pack
Não incluído neste pack**

**+ 9 AÑOS
Extreme *******

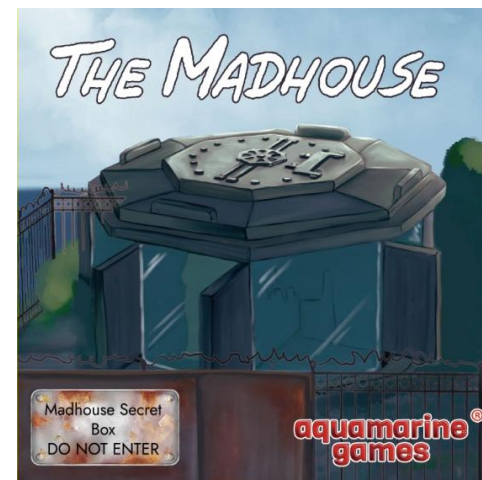

FABRICADO POR /MANUFACTURE BY:

COMPUDID S.L. ART. N: CP093

C/Angelita Camarero 5C

28035 Madrid-Spain

Tel: 34 913162613

customerservice@aquamarinegames.es

¡Advertencia!: No conviene a menores de 36 meses. Piezas Pequeñas. Warning: Not suitable for children under 36 months. Small parts. Aviso: Não adequado para crianças com menos de 36 meses. Peças pequenas.